

**HL868BA**

# **AUTOMATIC INFLATION BLOOD PRESSURE MONITOR**

Features:

- Personal Alert Level
- Irregular Heartbeat Detector
- Thin, Lightweight Design
- 3 Zones of 80 Memory - 240 Memory Total
- Memory Average of Last 3 Measurements
- Multi Measurement Options
- Time and Date Indications



## **Instruction Manual**

# Contents

1. What is blood pressure?.....	3
2. Why is it useful to measure blood pressure at home?....	3
3. Important information before use of the unit.....	5
4. Device description.....	6
5. Features .....	8
6. Changing batteries.....	9
7. Attaching arm cuff.....	9
8. Description of display symbols.....	11
9. How to measure.....	12
10. Maintenance.....	18
11.Safe-keeping.....	18
12.How to prevent malfunction.....	19
13.Warning.....	19
14.Specifications ( As the first page ).....	20

# Instruction Manual

## MEDICAL DISCLAIMER

This manual and product are not meant to be a substitute for advice provided by your doctor or other medical professional.

You are not to use the information contained herein, or this product for diagnosing or treating a health problem or prescribing any medication. If you have or suspect that you have a medical problem, promptly consult your healthcare provider.

**Model number: HL868BA**

### ***Arm Type Blood Pressure Monitor Intended Usage:***

Measures human's Systolic blood pressure, Diastolic blood pressure and heart pulse on upper arm by oscillometric measurement method.

The product is recommended for use by people over the age of 18 and is home use and not clinical use.

# 1

## **What is blood pressure ?**

Blood pressure is the pressure or the force of blood flowing against the walls of the arteries. Blood pressure is constantly changing during the course of the cardiac cycle. Systolic blood pressure is the highest pressure in the cycle. Diastolic blood pressure is the lowest pressure in the cycle. Both pressure readings, the Systolic rate and the Diastolic rate, are information for the physician to evaluate the status of patient's blood pressure. Many factors such as physical activities, anxieties, time of day, can influence one's blood pressure. Blood pressure is typically low in the morning and increases from afternoon to the evening. It is lower in the summer and higher in the winter.

# 2

## **Why is it useful to measure blood pressure at home ?**

Because having one's blood pressure measured by a doctor in a hospital, or clinic tends to stimulate nervousness in a person and may cause the blood pressure to rise. Also, blood pressure changes in different conditions, so judgement on the basis of single measurement is not reliable.

The blood pressure measured first thing in the morning after getting up, before taking any food is known as the fundamental blood pressure. So it is useful to take blood pressure at home.

# Why is it useful to measure blood pressure at home ?

## New W.H.O blood pressure classifications

Standards for assessing high or low blood pressure without regard to age have been established by the World Health Organization (WHO) as shown in the chart.

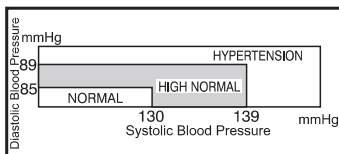

\* Figure No.1

## Variations in blood pressure

Individual blood pressures vary greatly on a daily and seasonal basis. These variations are even more pronounced in hypertension patients. Normally the blood pressure rises while at work and is at its lowest during sleep.

**(hypertension: means a person who has high blood pressure symptom.)**

The graph below illustrated the variations in blood pressure over a whole day with measurement taken every five minutes.

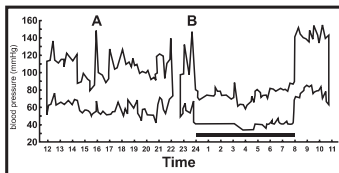

\* Figure No.2

(The thick line represents sleep. The rise in blood pressure at 4 PM ( A in the graph) and 12 PM( B in the graph) correspond to an attack of pain.



## **Important information before use of the unit**

- Blood pressure measurements should be interpreted by a physician or trained health professional who is familiar with one's medical history. By using the unit regularly and recording the results for the physician to interpret, one can keep physician informed of the continuing trends in one's blood pressure.
- Wrap the cuff snugly around your arm, The cuff must be at the same level as your heart.
- Do not move the unit during measurement, or accurate measurement can not be achieved.
- Take measurement in a relaxed position without talking.
- Do not wrap the cuff over jacket / sweater sleeve , or measurement cannot be done.
- Keep in mind that blood pressure naturally varies from time to time through out the day and is affected by lots of different factors such as smoking, alcohol consumption, medication, and physical activities.
- Blood pressure measurement determined by the unit are equivalent to those obtained by a trained observer using the cuff / stethoscope auscultation method, and is within the limits prescribed by the American National Standard for Electronic or Automated Sphygmomanometers.

# 4 Device Description

## A. Name of the parts

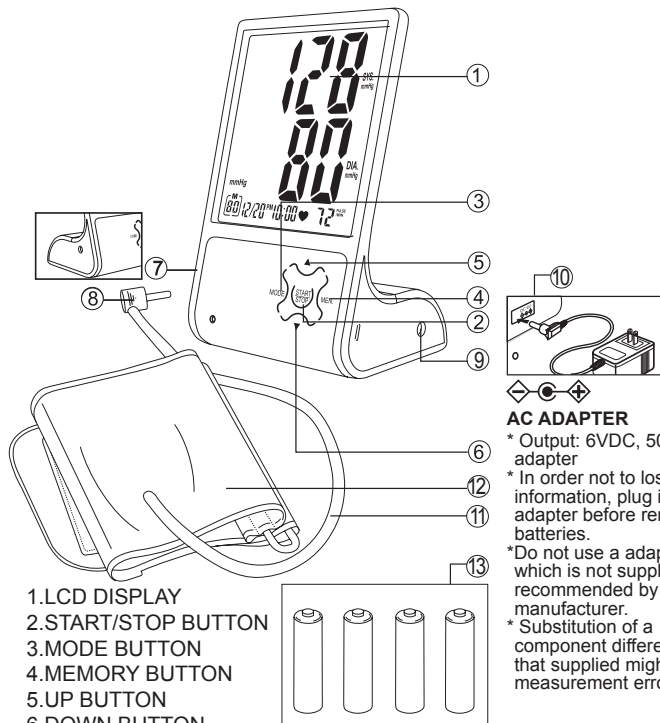

- 1.LCD DISPLAY
- 2.START/STOP BUTTON
- 3.MODE BUTTON
- 4.MEMORY BUTTON
- 5.UP BUTTON
- 6.DOWN BUTTON
- 7.AIR PLUG JACK
- 8.AIR PLUG
9. AC JACK
10. AC ADAPTER(OPTIONAL)
- 11.CUFF TUBE
- 12.CUFF
- 13.4 AA (1.5V) ALKALINE BATTERIES

### AC ADAPTER

\* Output: 6VDC, 500mA, AC adapter

\* In order not to lose stored information, plug in the AC adapter before removing batteries.

\* Do not use a adapter which is not supplied or recommended by the manufacturer.

\* Substitution of a component different from that supplied might result in measurement error.

# 4 Device Description

## B. Description of display symbols

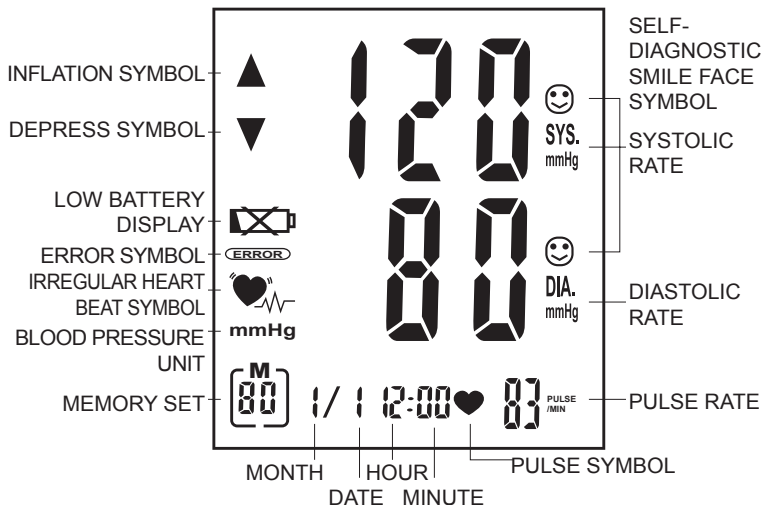

## At Rest Screen

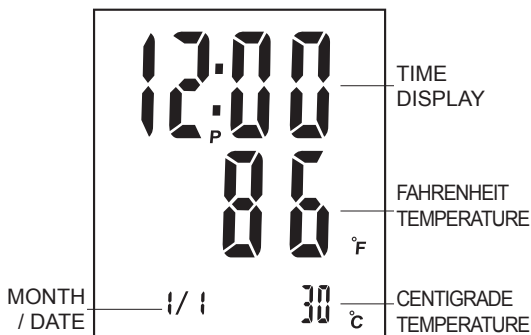

## Note:

- \* Ambient temperature will respond to the change of environment slowly.
- \* The temperature value might be a little bit higher if multiple measurements are being taken continuously.



# 5

## Features

- ***Quiet Inflation***

A unique, low noise, rolling motor system allows our monitors to inflate quietly.

- ***Large 3 Row Display Screen***

To make reading your result easier, the monitor comes with a large 3 row LCD display screen.

- ***Personal Alert Level***

If the Systolic or Diastolic rate of your reading result is greater than your set personalized level, the result on screen will flash.

- ***Irregular Heartbeat Detector***

This symbol will appear on left of screen indicating an irregular heartbeat was detected.

- ***Multi Measurement Options***

The monitor can be set to automatically take multiple (3 or 5) measurements and select the middle reading as your result.

- ***Memory Feature***

Your HL868BA Automatic Inflate Monitor features memory capability of up to 240 measurements and provides the average of the 3 most recent readings!

- ***Time and Date***

The monitor will automatically keep track of the time and date.

# 6

## Changing batteries

Remove the battery cover at the rear side of the unit and insert ALKALINE batteries into the battery compartment as shown, Make sure the polarities + and - are observed.

Important notice :

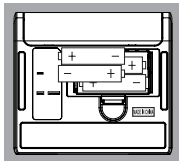
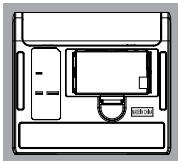

# 7

## Attaching arm cuff

- Press your brachial artery by two fingers approximately 1 inch above the elbow on the inside of your left arm.
- Determine where your strongest pulse is. Slide the end of arm cuff furthest from the tube through the metal ring to a loop. The smooth cloth should be on the inside of the cuff.
- If the cuff is located correctly, the Velcro will be on the outside of the cuff and metal ring will not touch your skin.
- Put left arm through the cuff loop. The bottom of the cuff should be approx. 0.5 inch above elbow. The cuff should lie over the brachial artery on the inside of the arm.

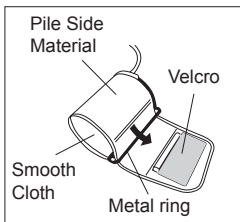
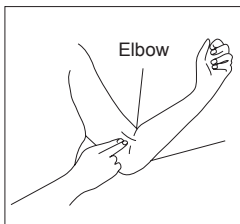

## 7 Attaching arm cuff

- Pull the cuff so that the top and bottom edges are tightened around your arm.

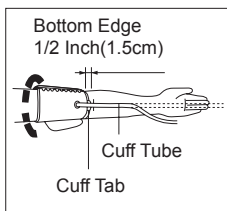

- When the cuff is positioned properly, press the Velcro firmly against the pile side of the cuff.

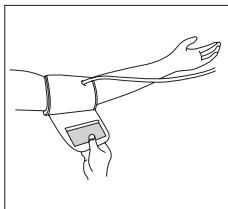



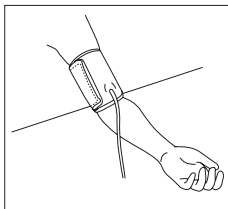

- Sit on a chair and place your arm on the table so that the cuff is at the same level as your heart.

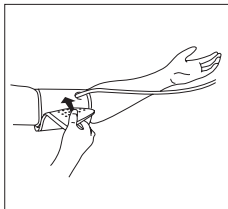

- Relax your arm and turn your arm upward.
- Make sure there are no kinks in the air tube.



## 8 Description of display marks

Display mark	Condition/Cause	Corrective action
 <b>pulse mark</b>	Flashes on the LCD screen when pulse is detected during measurement.	Measurements in progress. Do not move or talk.
 <b>replace batteries</b>	Appears when the battery voltage is excessively low or the positions of batteries are incorrect.	Replace all four batteries with new ones. Insert the batteries in correct polarities.
 <b>measuring error</b>	Appears when measurement error occurs or the blood pressure value is displayed excessively low or high.	Check if the cuff is wrapped properly around the wrist according to instructions. Ensure that your posture is correct and you remain perfectly still and quiet during the measurement. Measure again.
	Air circuit abnormality.	Check if the cuff is wrapped properly around the wrist. Measure again.
	Inflation pressure exceeding 300 mmHg.	Turn the device off, then measure again.
	Error determining measurement data.	Measure again.
 <b>IHB symbol</b>	Appears for 1 minute when the user was talking, moving or shaking or an irregular heart beat was detected during measurement.	Repeat the measurement. Note that you be relaxed for at least 5 minutes and sit comfortably and quietly before you restart a measurement.

# 9

## How to measure

### 1. Inserting 4 pieces "AA" Alkaline batteries in position:

- Open battery cover
- Refer to the picture in positioning batteries
- All segments will appear on the display in 3 seconds.
- Display 1 month 1 date, 12 hour 0 minute.



### 2. Setting Month, Date and Time :

- Press "MODE" button ("month" starts flashing)  
Press "▲" and "▼" button to set and adjust the correct month (1, 2, 3 ....12).
- Press "MODE" button again ("date" starts flashing)  
Press "▲" and "▼" button to set and adjust the correct date.
- Press "MODE" button again ("hour" starts flashing)  
Press "▲" and "▼" button to set and adjust the correct hour in 12-hour format. A "PM" will appear for PM and disappear for AM.
- Press "MODE" button again ("minute" starts flashing)  
Press "▲" and "▼" button to set and adjust the correct minute (00, 01, 02 ...59).

**If the batteries have run down or are removed or the adapter has been unplugged, the time and date will have to be reset.**

After setting the minute you will automatically be prompted to set the personalized level for Memory Zone 1. The storage of 240 memory readings is divided into 3 memory zones, each maintaining up to 80 memory readings. The following explains how to set your personalized level in each zone.

# 9

## How to measure

Your personalized level should be decided between you and your healthcare provider.

Before setting your levels it is important to know:

\*Your systolic rate is set between 70 and 250 mmHg.

\*Your diastolic rate is set between 40 and 115 mmHg.

### 3. Setting personalized levels

- a. Press "MODE" button (" - - " will flash for 1st systolic self-management)

Press "▲" or "▼" button to set/adjust the personalized systolic rate

- b. Press "MODE" button (" - - " will flash for 1st diastolic self-management)

Press "▲" or "▼" button to set/adjust the personalized diastolic rate

- c. Press "MODE" button (" - - " will flash for 2nd systolic self-management)

Press "▲" or "▼" button to set/adjust the personalized systolic rate

- d. Press "MODE" button (" - - " will flash for 2nd diastolic self-management)

Press "▲" or "▼" button to set/adjust the personalized diastolic rate

- e. Press "MODE" button (" - - " will flash for 3rd systolic self-management)

Press "▲" or "▼" button to set/adjust the personalized systolic rate

- f. Press "MODE" button (" - - " will flash for 3rd diastolic self-management)

Press "▲" or "▼" button to set/adjust the personalized diastolic rate

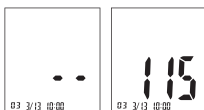
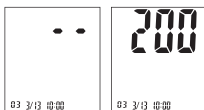
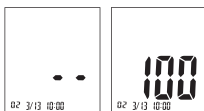
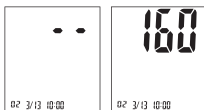
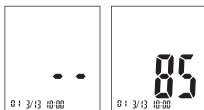
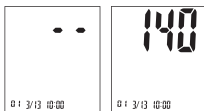
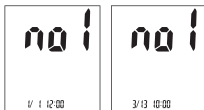

# 9

## How to measure

The examples above illustrate setting personalized levels in all 3 zones. After setting your Personalized Alert Level, you will automatically be given the option to set a Multi-Measurement for that zone. If you choose not to set a Multi-Measurement for that zone, just enter 1. After entering these settings you will be returned to the Rest mode and can take a measurement by pressing START/STOP.

### 4. Steps to take blood pressure measurement :

- Wrap the cuff around the arm (refer to previous page)
- Sit upright in a chair with feet flat on the floor.
- Press "▲" or "▼" button to select a particular memory zone then press the "START/STOP" button to start the measurement. The monitor will automatically inflate to the level that is right for you.
- When taking repeat measurements, make sure to select the same memory zone before pressing "START/STOP", so the measurement is registered to the appropriate memory.
- If the result of your Systolic or Diastolic rate of your reading result is greater than (not equal to) your set personalized level the DIGIT will flash. In addition the measurement that is out of range, either Systolic or Diastolic, will flash. If both are out of range both will flash. If the result of your Systolic or Diastolic rate of your reading result is equal or less than your set personalized level a SMILING symbol will show out and flash on screen.

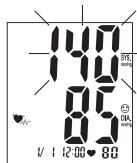
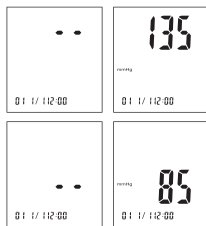

# 9

## How to measure

The appearance of this symbol, , signifies that a certain pulse irregularity was detected during the measurement. Talking, moving, shaking or an irregular pulse during the measurement can result in the appearance of this icon. Usually this is not a cause for concern, however if the symbol appears often, we recommend you seek medical advice. The device does not replace a cardiac examination, but serves to detect pulse irregularities at an early stage.

- To stop a reading in process, press the "START/STOP" button.
- Press and hold "Mode" button to check the pre-set personalized level.

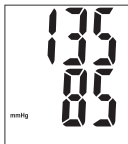

### 5. Storing, recalling, and erasing measurement data :

#### • Storing data

\*After each measurement, the systolic and diastolic rates, pulse rate and the time & date will be automatically stored. The memory holds data for the latest 80 measurements in each of 3 memory zones. If more than 80 measurements are entered, the memory will automatically clear out the oldest data.

#### • Recalling data

\*Press the "▲" or "▼" button to select the memory zone.

\*Press the "MEM" button to get your stored memory data. If there is no data in the memory nothing will appear.

\*If there is data in the memory, the first reading will be an average of the last three recorded set of measurements (systolic and diastolic pressure and pulse rate).





# 9

## How to measure

- \*Press the "MEM" button again and the latest recorded set of measurements will appear along with the recording time and date.
- \*Press the "▼" button to read the next set of stored data. The data displayed starts with the most recent reading and continues backwards to the oldest.
- \*If your memory readings are out of range of your preset personal Alert levels. They will flash or show SMILING FACE symbol as explained on the previous page.
- \*No Irregular Heartbeat Detector Record will be stored in memory.

### • Erasing data

- \*Press "MEM" into Memory mode.
- \*Press and hold on "MODE" button and then press "▲" button, the preset Personal Alert Level and all measurement data will be erased.
- \*To confirm the data has been erased, press the "MEM" button and no data should appear.

### **Note: 3 Zones of 80 Memory**

When you take a measurement, the monitor automatically stores it in memory space number one. As you continue to take measurements, the monitor will push the previous measurement back one space. In other words, the value in space one will always be the most recent blood pressure measurement taken.

Your monitor features a 3 party memory capability or 3 "zones" - each zone stores 80 measurements each for a total capacity of 240 measurements. This feature is useful for a user to track their blood pressure throughout the various periods of the day: morning, afternoon, and night. Press the "▲" button to toggle between memory zone No.1, 2, and 3. Once you select a zone that you want to view the measurements in, press the "MEM" button once to view the most recent measurement along with the time and date that it was taken.

# 9

## How to measure

Press the "MEM" button again in succession and you will see all of the measurements registered to that zone. You can then press the "▲" button to switch to the next zone to view measurements. The monitor will automatically power off after about one minute of inactivity.

**\*When taking measurements, be sure and select the correct zone number using the SET button so that the measurement is registered to the appropriate zone.**

### 6. Multi-Measurement Options

#### Setting Multi-Measurement

- a. Press the MODE button repeatedly until the figure below shows on the screen.

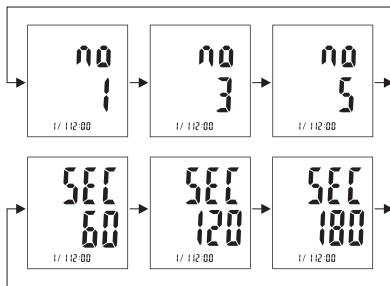

- b. Press "▲" to select 1, 3 or 5 measurements. When set to 1 the reading is a typical single measurement.
- c. Press "MODE" button ("60" starts flashing).
- d. Press "▲" to set/adjust the time between readings; 60, 120 or 180 seconds.
- e. Press the START/STOP button to start measurements.
- f. The monitor will show 2 bars (--) on the Systolic and Diastolic display when each measurement ends.
- g. After all measurements have been taken, the middle reading of each Systolic, Diastolic and Pulse reading will be displayed on the screen.

# 9

## How to measure

### 7. To change batteries:

When "  " show up on the display, the battery is weak. Take out all four batteries and put in 4 pcs of new Alkaline batteries.

All batteries used must be the same type. Do not mix alkaline, standard (carbon-zinc) or rechargeable (cadmium) batteries.

Do not mix old and new batteries.

# 10

## Maintenance

- Use a piece of cloth with water or mild cleansing agent to clean the case and then use a piece of dry cloth to wipe it dry. Use a piece of dry cloth to wipe the cuff when it is dirty.
- Do not use gas or any strong cleansers in cleaning.
- When the unit is not to be used for a long time, remove the batteries. (Leaking of battery liquid can cause trouble.)

# 11

## Safe-Keeping

- Always keep the unit in the carrying case after its use.
- Do not put the item directly under the sunlight, in high temperature, or humid and dusty places.
- Do not store in extremely low (less than  $-20^{\circ}\text{C}$ ) or high (more than  $70^{\circ}\text{C}$ ) temperature.

## 13 To Prevent Malfunction

- Do not in any way twist the arm cuff
- Do not start the start measurement when the arm cuff is not wrapped around the arm.
- Do not attempt to disassemble or change any parts of the monitor including the cuff.
- Do not drop the product or put it through strong impact.

## 13 Warning

- The cuff size is suitable for 23 ~ 33 cm / 9 ~ 13 inches adult only.
- The device is not supposed to be used when your arm has any wound or injury.
- In case the cuff kept pumping up non-stop, open the cuff at once.
- We do not recommend user to unpack the device by himself/herself to substitute of a component different from that supplied might result in measurement error.  
If any suggestion or service is requested please consult your service station.

# 14 To Prevent Malfunction

## Method of measurement Oscillometric

<b>Model Number</b>	HL868BA
<b>Range of measurement</b>	Pressure 0 ~ 300 mmHg Pulse 40 ~ 199 beats/minute
<b>Accuracy</b>	Pressure +/- 3 mmHg Pulse +/- 5% Max
<b>Inflation</b>	Automatic inflation (air pump)
<b>Exhaust</b>	Automatic exhaust valve
<b>Display</b>	Systolic, Diastolic, Pulse rate
<b>Sets of memory</b>	3 databases of 80 memory each = total 240 memory
<b>Cuff size</b>	Arm circumference approx. 23 ~ 33 cm/ 9 ~ 13 inch
<b>Operating Temperature</b>	+10 °C ~ +40 °C, less than 85% R.H.
<b>Storage Temperature</b>	-20 °C ~ +70 °C, less than 85% R.H.
<b>Unit Weight</b>	Approx. 265 g with battery
<b>Power Supply</b>	4 x "AA" (1.5 V), Alkaline Batteries Adapter(Optional): I/P: 230 VAC, 50 Hz (European area) O/P: 6 VDC, 1 A, 
<b>Battery Life</b>	300 times measurement (twice a day measurement)
<b>Auto Power Off</b>	Whenever not used for 1 minute
<b>Accessories</b>	4 batteries, arm cuff with tube, instruction manual, pouch, gift box , AC Adapter(optional)

\*These specifications are subject to change without notice for purpose of improvement.

## Note

**CE** 0197 This blood pressure monitor complies with the EC Directive and bears the CE mark

This blood pressure monitor also complies with mainly following standards (included but not limited):

Safety standard:

EN 60601-1 Medical electrical equipment part 1: General requirements for safety

EMC standard:

EN 60601-1-2 Medical electrical equipment part 1-2:  
General requirements for safety- Collateral  
standard: Electromagnetic compatibility-  
Requirements and tests

Performance standards:

EN 1060-1 Non-invasive sphygmomanometers - General requirements

EN 1060-3 Non-invasive sphygmomanometers  
- Supplementary requirements for  
electromechanical blood pressure measuring  
systems.

EN 1060-4 Non-invasive sphygmomanometers - Test  
procedures to determine the overall system  
accuracy of automated non-invasive  
sphygmomanometers.



Important!/Caution/Note!  
Read the operating instructions.



Consult instructions thoroughly before use.

---

## Note



BF

### Classification:

- Internally powered equipment
  - BF type applied part
  - IPX0
  - Not suitable for use in presence of flammable anaesthetic mixture with air or with Oxygen or nitrous oxide
  - Continuous operation with short-time loading
- 



To avoid inaccurate results caused by electromagnetic interference between electrical and electronic equipments, do not use the device near a cell phone or microwave oven.

---



Discard the used product to the recycling collection point according to local regulations.

---



Manufacturer:

Health & Life Co., Ltd.

9F. No. 186 Jian Yi Road, Chung Ho City, Taipei,  
Taiwan

---

**EC** | **REP**

Authorized Representative in the European  
Community:

Innovative business promotion GmbH  
Botzstrasse 6, 07743 Jena, Germany

---













[www.healthandlife.net](http://www.healthandlife.net)

P/N: xxxxxxxxxx Rev.A-a 20090421

**HEALTH & LIFE CO., LTD.**